



TANK SENTRY

All Models
WTS-1100B, WTS-1500B, TS-1501B,
TS-2000B, & TS-2500B

INSTALLATION INSTRUCTIONS

NOVEMBER 2003, REV. 3

Doc No. XG-0030 Rev No. 052307

WELCOME!

Congratulations on your purchase of a Tank Sentry fluid level monitoring and control system. This guide will assist you in installation, calibration and set-up of your system.

We welcome your comments. If you have any questions or run into a technical difficulty, give us a call. Our experienced field engineers are standing by to assist you.

Headhunter Customer Service

(800) 662-8557

www.headhunterinc.com

INTRODUCTION

Tank Sentry is designed to be used on all water, oil, and diesel fuel based fluids. The signal is derived by measuring the pressure at the bottom of a tank as the fluid level changes. A small air compressor is built into the SYM-23QR or SYM-23QS Sensor Module and is activated automatically. This purges the air in the ¼-inch OD tubing that extends from the SYM to the bottom of the tank. A pressure transducer inside the SYM senses this pressure and converts it to an electrical signal that drives the Tank Sentry Panel. The compressor can be operated at any time by depressing the white purge button located near the wire and tubing ports on the SYM. **The SYM-23QR is recommended for tanks from 12” to 120”.** **The SYM-23QS is recommended for shallow tanks from 0” to 32”.**

PACKING LIST

The following components are shipped with each Tank Sentry:

Plastic series for water based fluids;

Qty	Part Number	Description
1	MO-1100, MO-1500, MO-1501, MO-2000, or MO-2500	Monitor Panel with mounting screws.
1	TIF-1250	1 ¼-inch MPT Schedule 80 PVC Tank Insert Fitting with 90° elbow.
1	SYM-23Q (R OR S)	Sensor Module.
2	NT-250	¼-inch OD straight nylon tubing, 34 inches long, used inside tank.
30 ft	MW-18/3S	18 gauge 3 conductor wire with shield, used between Sensor Module and Monitor Panel.
2	UN-250	¼-inch quick connect union, used at bottom of straight nylon tube.
2	CC-250	Collet Cover, used with union.
2	SSW-250	½-inch OD x ¼-inch ID x 1-inch L stainless steel weight, used at bottom of straight nylon tube.
3	HSBC-18	Pink 18 gauge heat shrink butt connectors.
2	LK-250	¼-inch Locking Snap Ring, used around tubing collet at Tank Insert Fitting, and Sensor Module.
10 ft	UT-250	¼-inch OD Ether Urethane tubing, inserted in collet at Sensor Module, and Tank Insert Fitting.

-FLGB Series (Brass Flange, Brass Fittings)

Qty	Part Number	Description
1	MO-1100, MO-1500, MO-1501, MO-2000, or MO-2500	Monitor Panel with mounting screws
1	TIF-SAEB	Brass SAE 5-hole flange assembly with bulkhead union, 90° elbow, and 34-inches of ¼-inch OD long nylon tubing (NT-250) attached. Includes gasket (TSGSK-SAE), and 5 stainless steel machine screws (TS1032-100).
1	SYM-23Q (R OR S)	Sensor Module
1	NT-250	¼-inch OD straight nylon tubing, 34 inches long, used inside tank
30 ft	MW-18/3S	18 gauge 3 conductor wire with shield, used between Sensor Module and Monitor Panel
2	UN-250	¼-inch quick connect union, with 1 tubing collet cover per union, used at bottom of straight nylon tube
2	CC-250	Collet Cover
2	SSW-250	½-inch OD x ¼-inch ID x 1-inch L stainless steel weight, used at bottom of straight nylon tube
3	HSBC-18	Pink 18 gauge heat shrink butt connectors
10 ft	TSPB-4YW	Yellow Swagelok® ¼-inch hose
2	TSPB-TA4	Brass Swagelok® push-on tube adapters (supplied pre-installed on hose).

-FLGA Series (Aluminum Flange, Stainless Steel Fittings)

Qty	Part Number	Description
1	MO-1100, MO-1500, MO-1501, MO-2000, or MO-2500	Monitor Panel with mounting screws
1	TIF-SAEA	Aluminum SAE 5-hole flange assembly with bulkhead union, 90° elbow, and 34-inches of ¼-inch OD long nylon tubing (NT-250) attached. Includes gasket (TSGSK-SAE), and 5 stainless steel machine screws (TS1032-100).
1	SYM-23Q (R OR S)	Sensor Module
1	NT-250	¼-inch OD straight nylon tubing, 34 inches long, used inside tank
30 ft	MW-18/3S	18 gauge 3 conductor wire with shield, used between Sensor Module and Monitor Panel
2	UN-250	¼-inch quick connect union, with 1 tubing collet cover per union, used at bottom of straight nylon tube
2	CC-250	Collet Cover
2	SSW-250	½-inch OD x ¼-inch ID x 1-inch L stainless steel weight, used at bottom of straight nylon tube
3	HSBC-18	Pink 18 gauge heat shrink butt connectors
10 ft	TSPB-4YW	Yellow Swagelok® ¼-inch hose
2	TSPS-TA4	Stainless Steel Swagelok® push-on tube adapters (supplied pre-installed on hose).

Note: Swagelok is a registered trademark of Swagelok Co.

-FLGS Series (Stainless Steel Flange, Stainless Steel Fittings)

Qty	Part Number	Description
1	MO-1100, MO-1500, MO-1501, MO-2000, or MO-2500	Monitor Panel with mounting screws
1	TIF-SAES	Stainless Steel SAE 5-hole flange assembly with bulkhead union, 90° elbow, and 34-inches of ¼-inch OD long nylon tubing (NT-250) attached. Includes gasket (TSGSK-SAE), and 5 stainless steel machine screws (TS1032-100).
1	SYM-23Q (R OR S)	Sensor Module
1	NT-250	¼-inch OD straight nylon tubing, 34 inches long, used inside tank
30 ft	MW-18/3S	18 gauge 3 conductor wire with shield, used between Sensor Module and Monitor Panel
2	UN-250	¼-inch quick connect union, with 1 tubing collet cover per union, used at bottom of straight nylon tube
2	CC-250	Collet Cover
2	SSW-250	½-inch OD x ¼-inch ID x 1-inch L stainless steel weight, used at bottom of straight nylon tube
3	HSBC-18	Pink 18 gauge heat shrink butt connectors
10 ft	TSPB-4YW	Yellow Swagelok® ¼-inch hose
2	TSPS-TA4	Stainless Steel Swagelok® push-on tube adapters (supplied pre-installed on hose).

-BRS Series (Brass Threaded Insert and Fittings)

Qty	Part Number	Description
1	MO-1100, MO-1500, MO-1501, MO-2000, or MO-2500	Monitor Panel with mounting screws
1	TIF-1250-BRS	1 ¼-inch MPT Brass Tank Insert Fitting with bulkhead union, 90° elbow, and 34-inches of ¼-inch OD long nylon tubing (P/N NT-250) attached.
1	SYM-23Q (R OR S)	Sensor Module
1	NT-250	¼-inch OD straight nylon tubing, 3 ft long, used inside tank
30 ft	MW-18/3S	18 gauge 3 conductor wire with shield, used between Sensor Module and Monitor Panel
2	UN-250	¼-inch quick connect union, with 1 tubing collet cover per union, used at bottom of straight nylon tube
2	CC-250	Collet Cover
2	SSW-250	½-inch OD x ¼-inch ID x 1-inch L Stainless Steel Weight, used at bottom of straight nylon tube
3	HSBC-18	Pink 18 gauge heat shrink butt connectors
10 ft	TSPB-4YW	Yellow Swagelok® ¼-inch hose
2	TSPB-TA4	Brass Swagelok® push-on tube adapters (supplied pre-installed on hose).

Note: Swagelok is a registered trademark of Swagelok Co.

-SST Series (Stainless Steel Threaded Insert and Fittings)

Qty	Part Number	Description
1	MO-1100, MO-1500, MO-1501, MO-2000, or MO-2500	Monitor Panel with mounting screws
1	TIF-1250-SST	1 ¼-inch MPT Stainless Steel Tank Insert Fitting with bulkhead union, 90° elbow, and 34-inches of ¼-inch OD long nylon tubing (P/N NT-250) attached.
1	SYM-23Q (R OR S)	Sensor Module
1	NT-250	¼-inch OD straight nylon tubing, 3 ft long, used inside tank
30 ft	MW-18/3S	18 gauge 3 conductor wire with shield, used between Sensor Module and Monitor Panel
2	UN-250	¼-inch quick connect union, with 1 tubing collet cover per union, used at bottom of straight nylon tube
2	CC-250	Collet Cover
2	SSW-250	½-inch OD x ¼-inch ID x 1-inch L Stainless Steel Weight, used at bottom of straight nylon tube
3	HSBC-18	Pink 18 gauge heat shrink butt connectors
10 ft	TSPB-4YW	Yellow Swagelok® ¼-inch hose
2	TSPS-TA4	Stainless steel Swagelok® push-on tube adapters (supplied pre-installed on hose).

FIGURE 1a: TANK SENTRY ASSEMBLY AND INSTALLATION
-PLASTIC SERIES

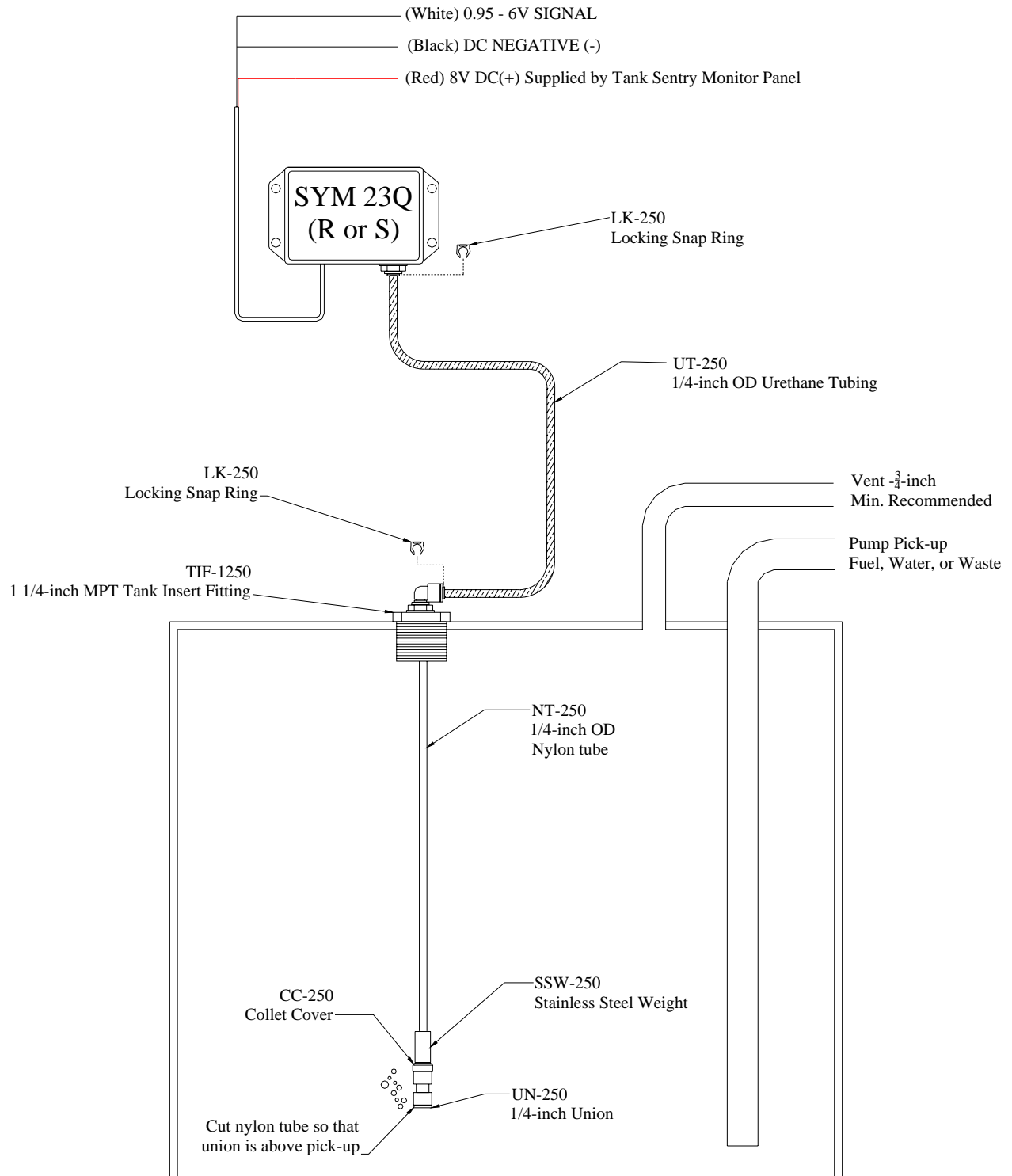
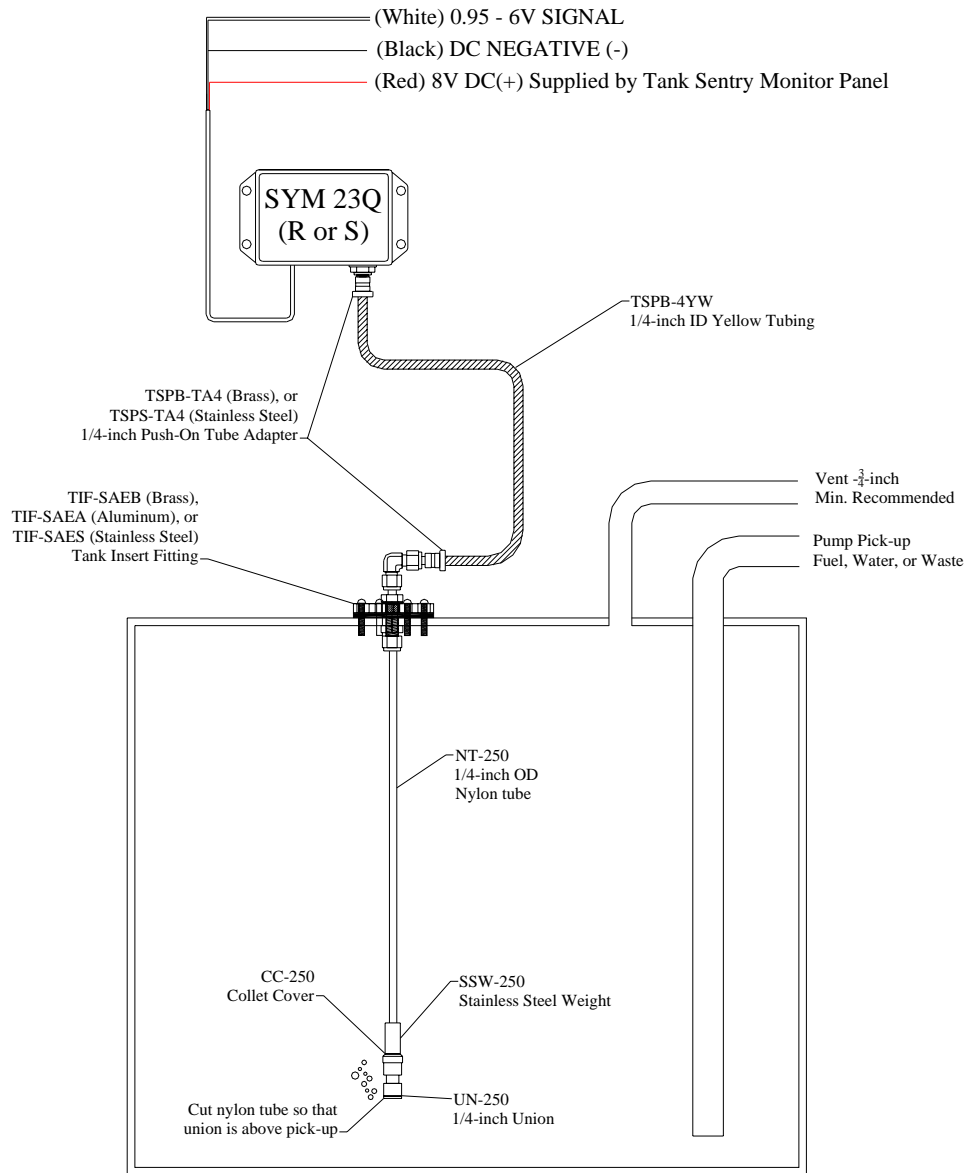

FIGURE 1b: TANK SENTRY ASSEMBLY AND INSTALLATION
-FLGB, -FLGA, & -FLGS SERIES



**FIGURE 1c: TANK SENTRY ASSEMBLY AND INSTALLATION
-BRS & -SST SERIES**

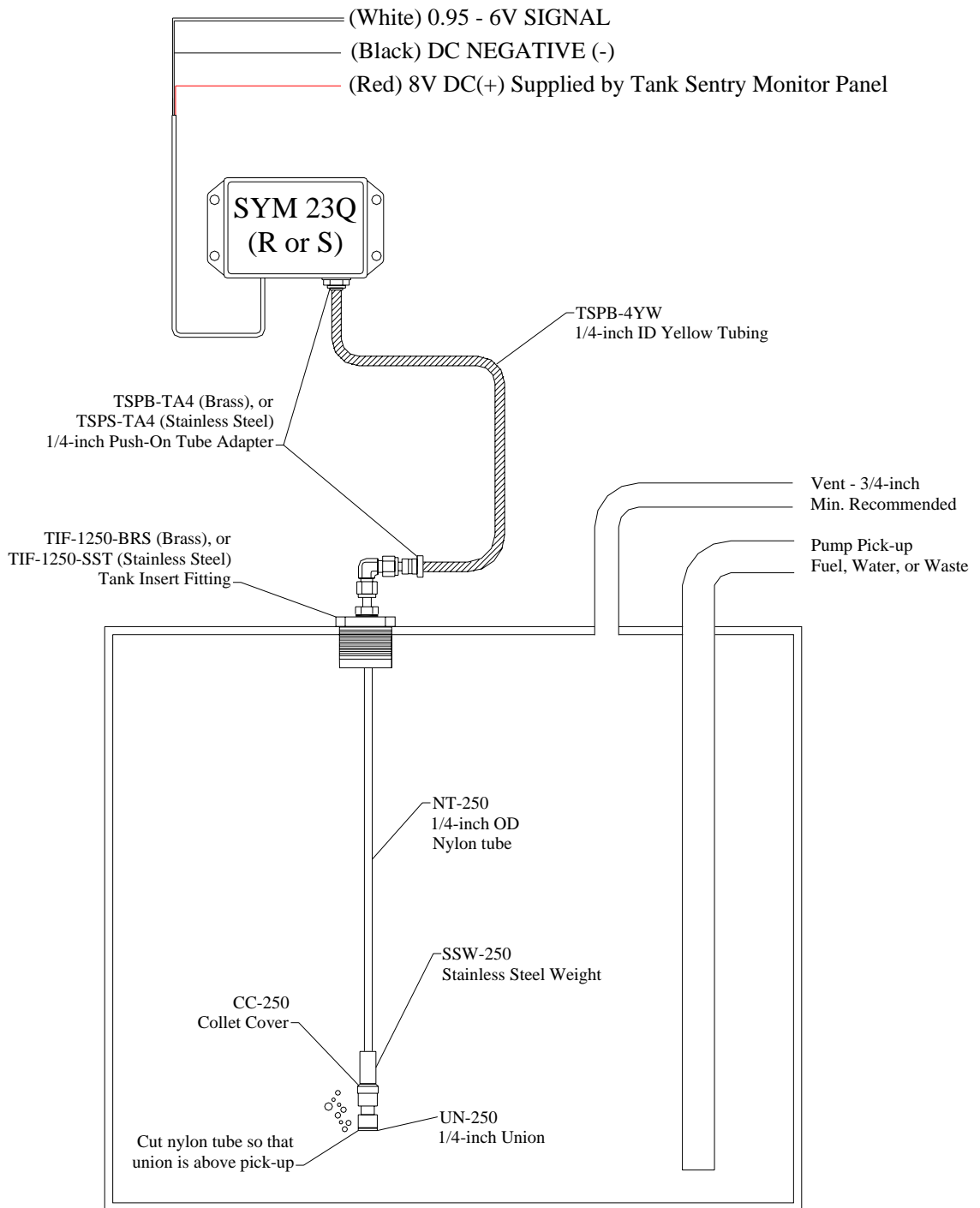

FIGURE 2a: DEEP TANK AND SIDE TANK INSTALLATION
-PLASTIC SERIES

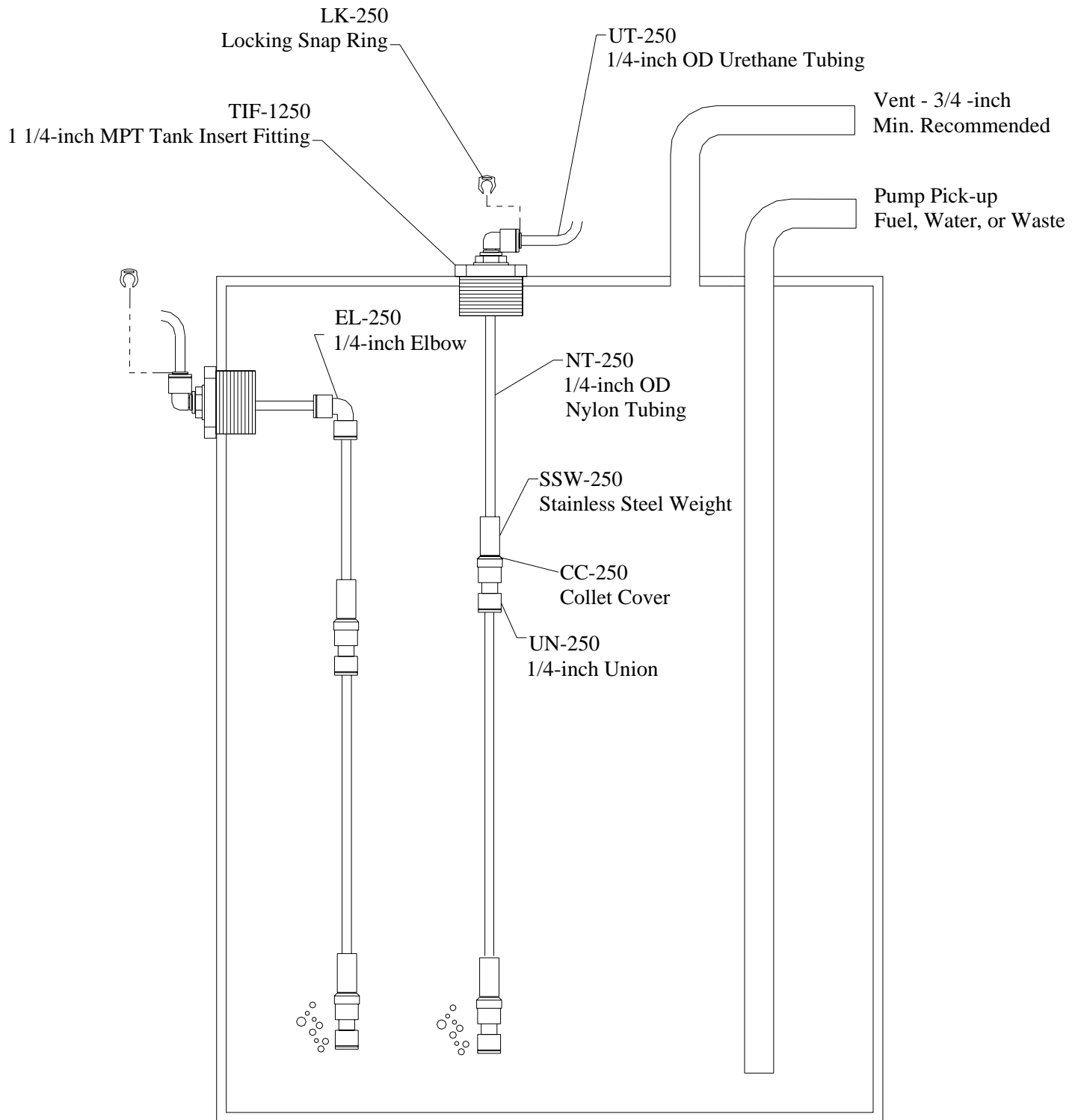

FIGURE 2b: DEEP TANK AND SIDE TANK INSTALLATION
-FLGB, -FLGA, & -FLGS SERIES

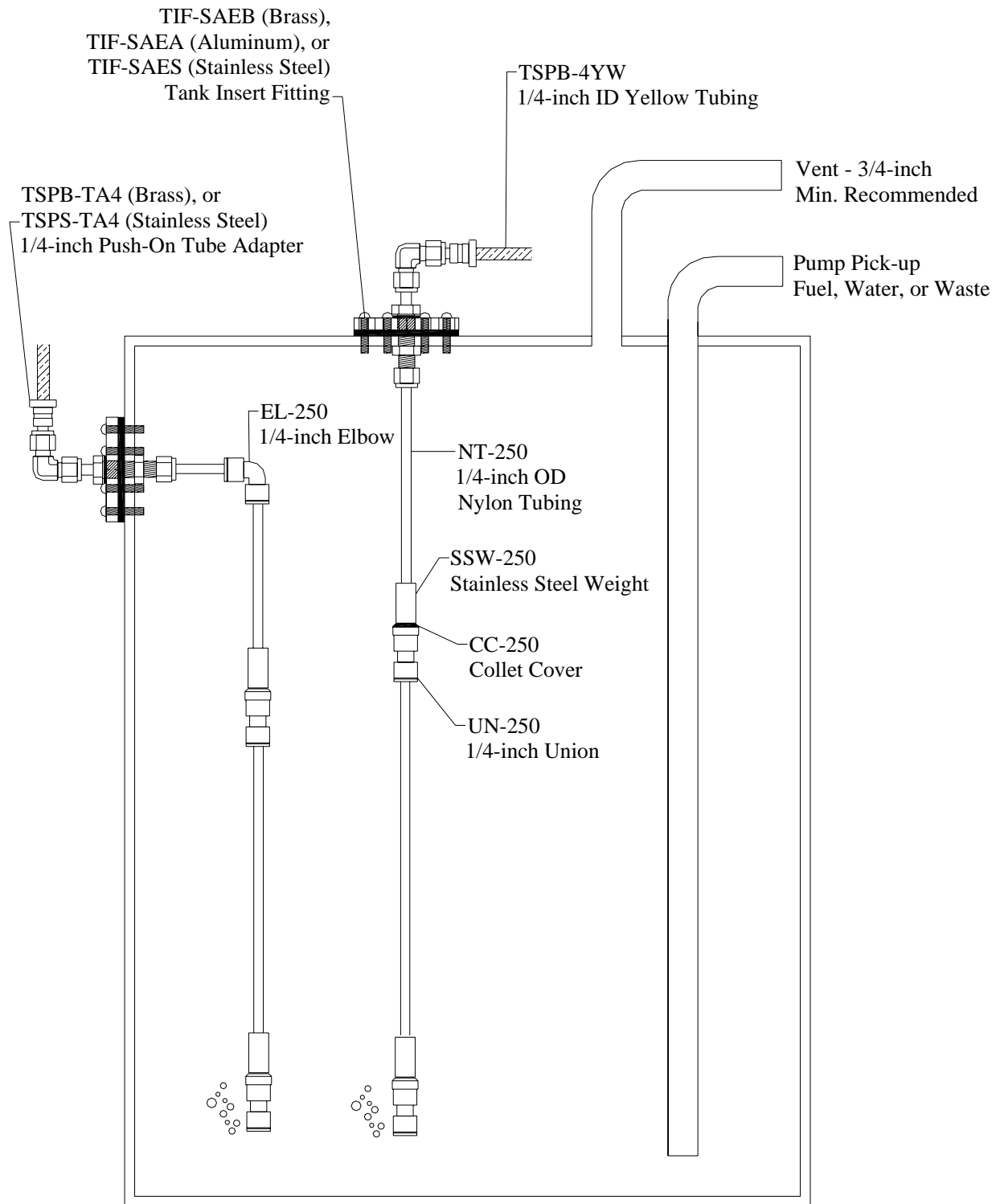
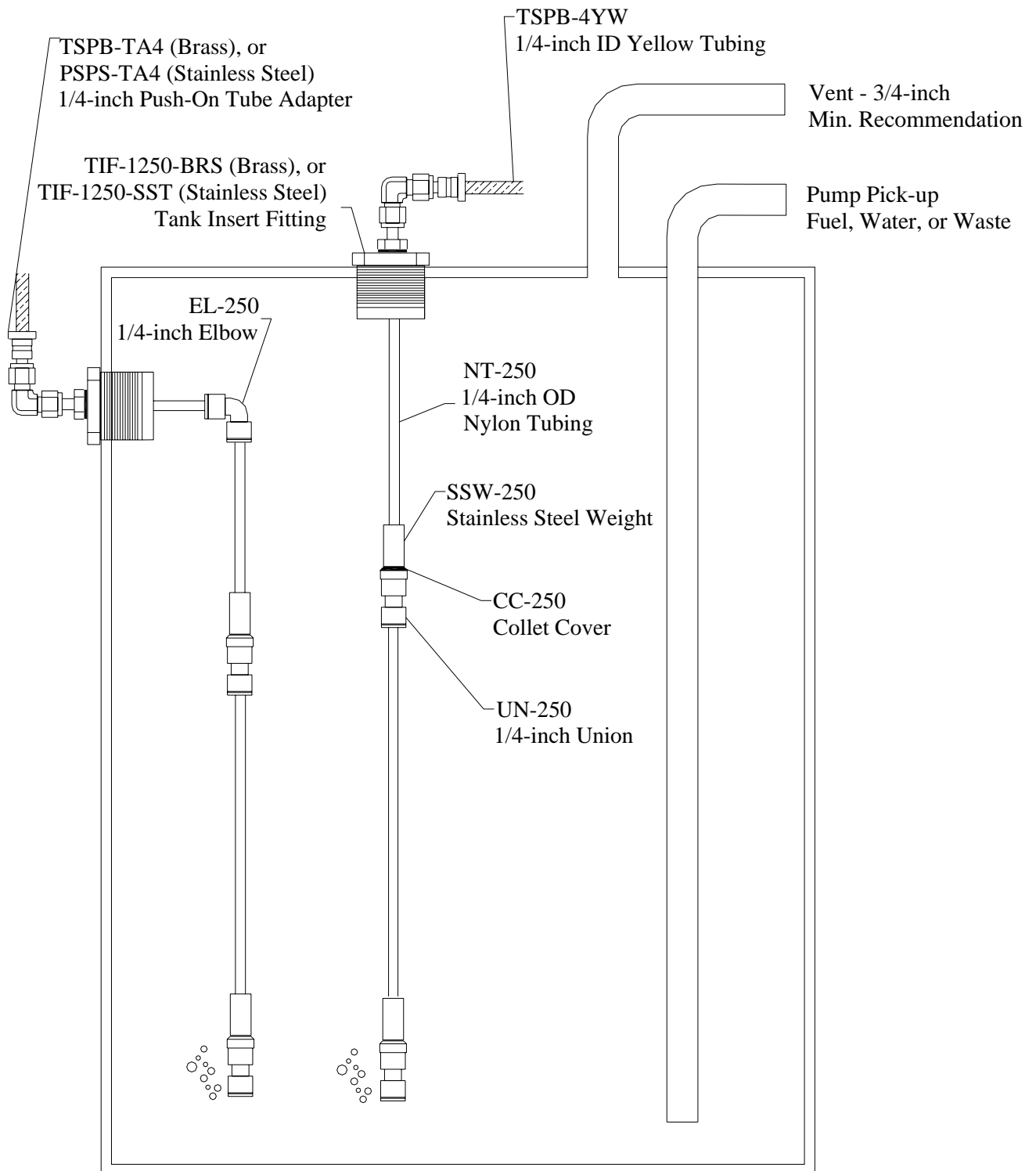

FIGURE 2c: DEEP TANK AND SIDE TANK INSTALLATION
-BRS & -SST SERIES



INSTALLATION OF PLASTIC TANK INSERT FITTING

Figures 1a and 2a show typical installations and the general configuration of the Tank Sentry system. Our Tank Sentries utilize unique quick-connect fittings that require no tools for installation. Figure 3a illustrates how the tubing connections are made. Note that once properly assembled, you should not be able to pull the tubing connection apart unless the darker gray collet is depressed.

1. Determine the depth of the tank and depth of any pump pickup tubes.
2. Cut the nylon tube so that its cut end will be suspended two inches above the pump pickup tube. See paragraph below for deep tank instructions.
3. Install the stainless steel weight, collet cover and union fitting. The stainless steel weight is provided to keep the end of the nylon tube from floating upwards. Slide the weight over the bottom end of the straight nylon tube after cutting. Slide on the collet cover underneath the weight. Press the bottom end of the straight nylon tube into the UN-250 union. Snap the collet cover into place over the darker gray collet. The collet cover prevents the weight from depressing the collet and disengaging the union.

Important: *The end of the nylon tube **must** be installed above the pick up tube for any installed pumps; otherwise your monitor may display fluid that you cannot pump. For example, if a WTS-1500 is configured with the nylon tube too long, and is set to automatically pump down the tank until it reads "0", the discharge pump may run continuously and incur damage.*

4. Apply appropriate pipe thread sealant to the male threads of the tank insert fitting (TIF-1250), and screw it into a 1 ¼-inch FPT tapered fitting located on the top or side of the tank.
5. Connect the UT-250 ether urethane tubing to the elbow fitting on the top of the tank insert fitting.
6. Connect the other end of the UT-250 tubing into the SYM-23Q (R or S) Sensor Module.

FIGURE 3a: PLASTIC TUBING CONNECTIONS

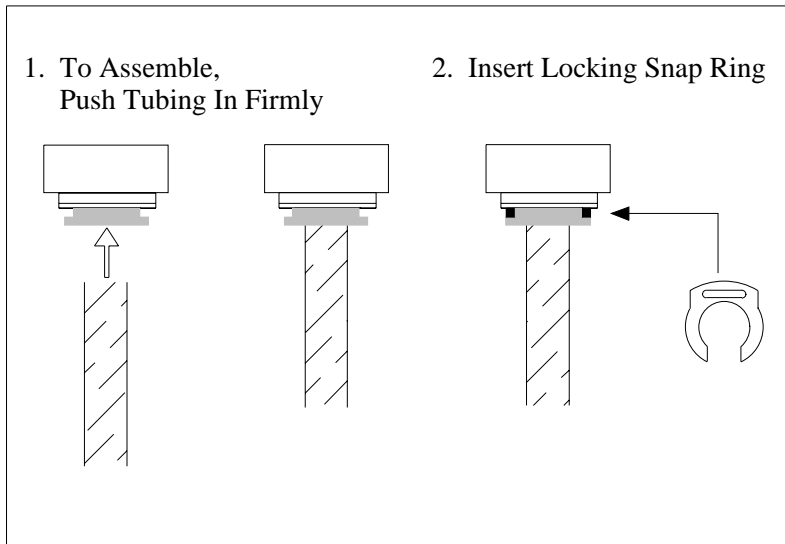

Note: To disassemble a tubing connection:

1. Remove the locking snap ring
2. Depress the gray collet
3. Remove the tubing.

DEEP TANKS

An extension kit is included for tanks deeper than 3 feet. Simply push the second piece of nylon tubing into the bottom of the UN-250 union, cut the tube to length, and install the second weight at the end as on the previous section. This configuration is shown in Figure 2a.

SIDE TANK INSTALLATIONS

If access to the top of the tank is unavailable, the tank insert fitting (TIF-1250) can be installed into the side of the tank. Order an EL-250, ¼-inch 90° elbow, from your nearest Headhunter representative. Assemble the elbow inside of the tank to direct the NT-250, ¼-inch OD straight nylon tubing to the bottom of the tank. This configuration is shown in Figure 2a.

A 1 ¼-inch FPT flange is available from your Headhunter representative. It can be mechanically fastened to the top or the side of the tank. It provides a threaded connection where you do not already have one.

INSTALLATION OF FLANGE OR TANK INSERT FITTING

Our –FLGB, –FLGA, –FLGS, –BRS, & –SST series Tank Sentries utilize high quality Swagelok® fittings that require minimal tools. Figures 1b, 1c, 2b, and 2c show typical installations.

1. Determine the depth of the tank and depth of any pump pickup tubes.
2. Cut the nylon tube so that its cut end will be suspended two inches above the pump pickup tube. See paragraph below for deep tank instructions.
3. Install the stainless steel weight, collet cover and union fitting. The stainless steel weight is provided to keep the end of the nylon tube from floating upwards. Slide the weight over the bottom end of the straight nylon tube after cutting. Slide on the collet cover underneath the weight. Press the bottom end of the straight nylon tube into the UN-250 union. Snap the collet cover into place over the darker gray collet. The collet cover prevents the weight from depressing the collet and disengaging the union.

Important: *The end of the nylon tube **must** be installed above the pick up tube for any installed pumps, otherwise your monitor may display fluid that you cannot pump. For example, if a WTS-1500 is configured with the nylon tube too long, and is set to automatically pump down the tank until it reads "0", the discharge pump may run continuously and incur damage.*

-FLGB, -FLGA, & -FLGS Only:

4. Place the gasket (TSGSK-SAE) over the tank opening, between the flange and the tank. Make sure that you correctly align the asymmetrical bolt pattern, then bolt the flange into the top of the tank using the #10/32 bolts provided.

-BRS & -SST Only:

4. Apply appropriate pipe thread sealant to the male threads of the tank insert fitting (TIF-1250 -SST, or –BRS), and screw it into a 1 ¼-inch FPT tapered fitting located on the top or side of the tank.
5. Connect the yellow Swagelok® tubing to the elbow fitting on the top of the flange or tank insert fitting. (See Figure 3b for detailed instructions).
6. Connect the other end of the yellow Swagelok® tubing into the SYM-23Q (R or S) Sensor Module.

FIGURE 3b: SWAGELOK CONNECTIONS

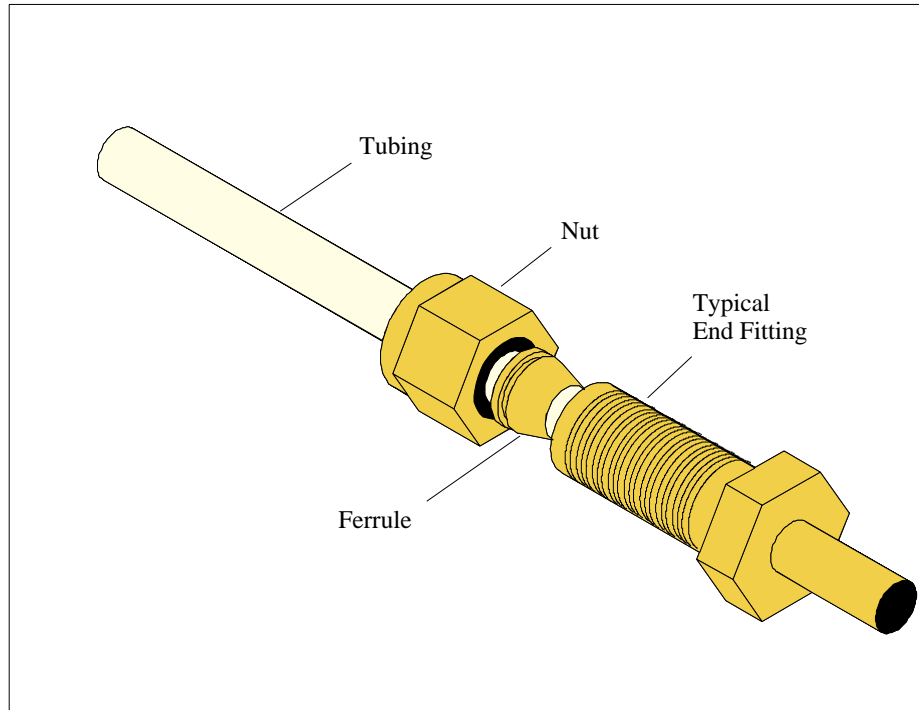

1. Insert the tubing into the Swagelok® fitting; making sure that the tubing rests firmly on the shoulder of the fitting. Figure 3b shows the internal components of the fitting for your information, but there should be no need to disassemble the fitting.
2. Tighten the nut finger tight, and then scribe the nut in the 6-o'clock position.
3. Hold the fitting steady with a back-up wrench and tighten the nut 1 ¼ turns from finger tight. Watch the scribe mark. Make one complete revolution and continue to the 9 o'clock position. This procedure will ensure that the nut has been properly tightened.

Swagelok® fittings can be disconnected and retightened many times. The same reliable leak-proof seal can be obtained every time the connection is remade. To reassemble a Swagelok® connection, simply insert the tubing with the pre-swaged ferrule into the fitting body until the ferrule seats. Tighten the nut by hand, and rotate the nut to its original position with a wrench. An increase in resistance will be encountered at the original position. Then tighten slightly with a wrench.

DEEP TANKS

An extension kit is included for tanks deeper than 3 feet. Simply push the second piece of nylon tubing into the bottom of the UN-250 union, cut the tube to length, and install the second weight at the end as on the previous section. This configuration is shown in Figures 2b and 2c.

SIDE TANK INSTALLATIONS

If access to the top of the tank is unavailable, the flange assembly (TIF-SAEB, -SAEA, or -SAES), or tank insert fitting (TIF-1250-SST, or -BRS) can be installed into the side of the tank. Order an EL-250, ¼-inch 90° elbow, from your nearest Headhunter representative. Assemble elbow inside of the tank to direct the NT-250, ¼-inch OD straight nylon tubing to the bottom of the tank. This configuration is shown in Figures 2b and 2c.

SYM-23Q (R OR S) SENSOR MODULE INSTALLATION

Select a dry, accessible location above the tank top to secure the SYM-23Q (R or S) sensor module. The sensor module cannot be submerged below water. Install with the tubing and cable port facing down or sideways (this prevents dust and debris from blocking intake filter).

Run the ¼-inch (O.D.) tubing from the tank penetration assembly to the sensor module. Secure the tubing so that no kinks occur, and firmly push the free end into the quick connect fitting of the SYM-23Q (R or S) Sensor Module.

The SYM-23Q (R or S) can be remote mounted up to 200 feet away from the tank penetration assembly. Contact your nearest Headhunter representative for the correct supplies. Substitutions are discouraged, and may void the warranty.

SYM-23Q (R OR S) OPERATION:

The SYM-23Q (R or S) continuously monitors the fluid level in the tank and converts it into a varying analog voltage signal of .95VDC to a max of 6VDC. A complete voltage description can be found in Appendix C.

Upon startup, the SYM-23Q (R or S) will purge for 15 seconds at full speed. After start up, it will purge at slower and considerably quieter speed whenever the fluid level in the tank changes by +/- 2" (inches) or 50 mm of fluid. Exactly every 24 hours after startup, the SYM will do a full speed purge for 5 seconds for maintenance purposes.

LED DIAGNOSTICS:

A bi-color LED mounted on the side of the SYM-23Q (R or S) is provided for system diagnostics.

A continuous green LED indicates the SYM-23Q (R or S) is powered up and has a stable signal voltage indicating there is some fluid in the tank and there are no leaks in the tubing.

A blinking green LED indicates the SYM-23Q (R or S) is monitoring a totally empty tank, and/or the tubing between the SYM and the tank penetration assembly is not connected properly.

A blinking red LED indicates the SYM-23Q (R or S) has detected a much smaller leak and has changed into a mode whereby it cycles once every 10 minutes for 3.5 seconds. During this condition the SYM will purge at full speed. Repair the leak, and reset the SYM to return to normal operation.

An orange LED indicates the SYM-23Q (R or S) is in a hold mode and will not cycle. This is helpful when using the Headhunter Calibration kit. See special note below for instructions on using the calibration kit option.

RESET:

To reset the SYM-23Q (R or S) and return it to normal operation, depress the white purge button on the SYM. The SYM will purge for 15 seconds and then return to normal operation.

Special note for installers using a Headhunter Tank Sentry Calibration Kit:

- Press white purge button twice.
- LED should turn orange. The SYM-23Q (R or S) is now in calibration kit mode and will not cycle for 10 minutes.
- Connect SYM-23Q (R or S) to calibration kit with ¼" OD tubing.
- Pump up calibration kit to desired fluid level on the gauge using calibration kit instructions.
- Calibrate tank sentry panel.
- Upon completion of calibration, connect the SYM-23Q (R or S) to the tank penetration assembly and push the white purge button again.

MOUNTING THE TANK SENTRY MONITOR PANEL

Select the site for the location of the Tank Sentry Panel. Figures 4a & 4b show the dimensions of the panel, and identify the area you need to cut out for mounting. For best results, use the actual Tank Sentry monitor panel as a template before making any cuts. After preparing the area where the panel is to be mounted, complete the following connections and calibrations prior to final attachment of the monitor. The monitor may be installed up to 100 feet from the SYM-23Q (R or S) Sensor Module. If the distance exceeds 30 feet, you'll need to order more MW-18/3S, shielded 18/3 cable. The panel should be installed in a dry location. It will be easier to read if it's not in direct sunlight.

FIGURE 4a: WTS-1500B, TS-1501B, AND TS-2000B SERIES MONITOR PANEL DIMENSIONS

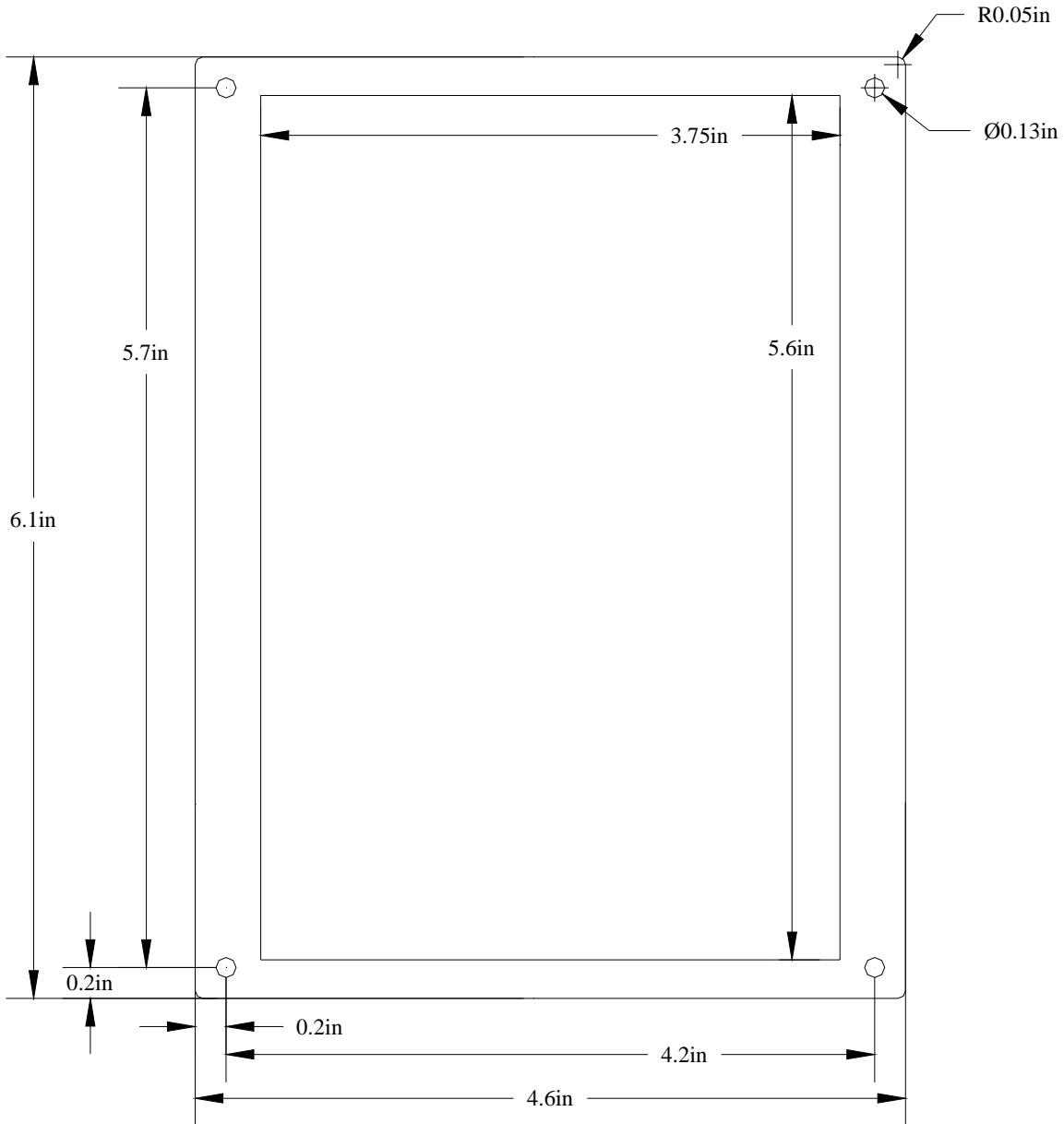

This drawing is intended as an installation guideline only, and should not be used as a cut-out template. For best results, use the actual Tank Sentry unit as a template before making any cuts.

FIGURE 4b: WTS-1100B AND TS-2500B MONITOR PANEL DIMENSIONS

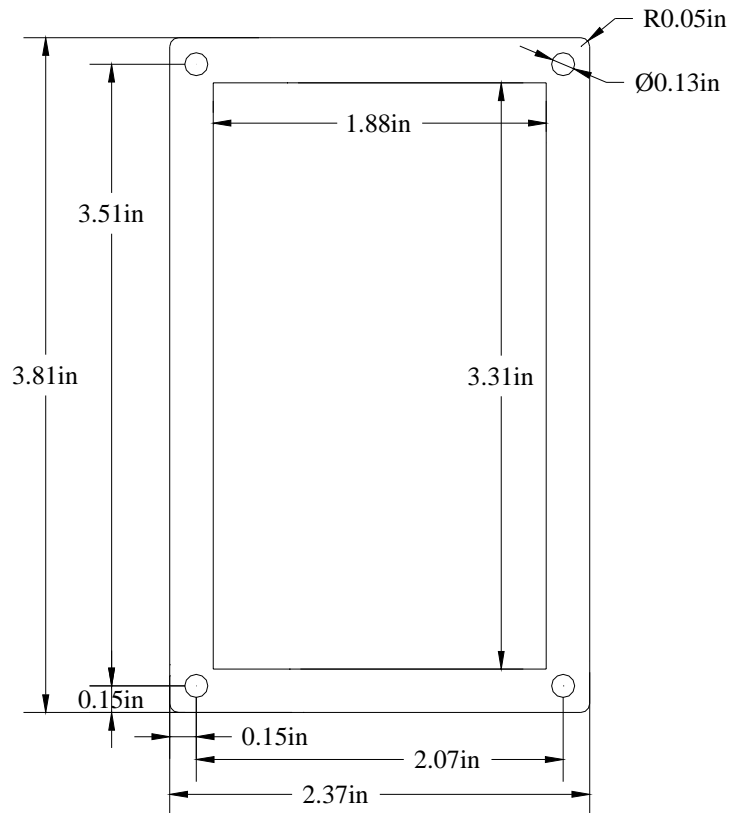

This drawing is intended as an installation guideline only, and should not be used as a cut-out template. For best results, use the actual Tank Sentry unit as a template before making any cuts.

ELECTRICAL CONNECTIONS TO THE MONITOR PANEL

Consult the attached circuit diagram (Figure 5) for correct wiring of the Tank Sentry.

- Make sure DC power is turned off before making wire connections. Do not wire from the hot side of a DC pump solenoid or voltage fluctuations may cause false readings. If a DC power supply instead of a battery is used, contact your Headhunter representative for proper application assistance. Certain types of power supplies (e.g. rectifiers) may cause faulty operation.
- Connect terminal 1 to DC system negative with 16 gauge wire.
- Connect terminal 2 to DC system Positive (12-36 VDC) through a suitable circuit protection device (e.g. 5 Amp breaker). Use 16 gauge wire.
- Terminals 5, 6, and 7 for WTS-1500B, TS-1501B, and TS-2000B and terminals 3, 4, and 5 for WTS-1100B and TS-2500B on the back of the monitor panel connect to the black (plus the shield), red, and white wires respectively of the MW-18/3S shielded wire from the SYM-23Q (R or S) Sensor Module.
- See figure below for supplying power to multiple monitors in a system. Be sure each Tank Sentry Monitor is *directly connected* to the power supply.

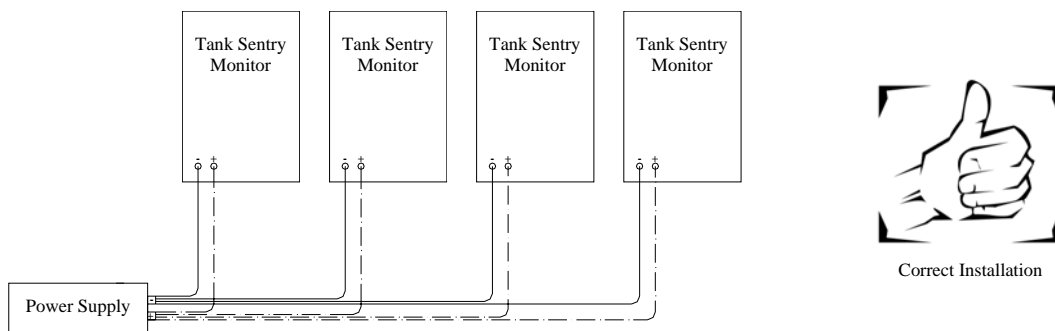

Correct Installation

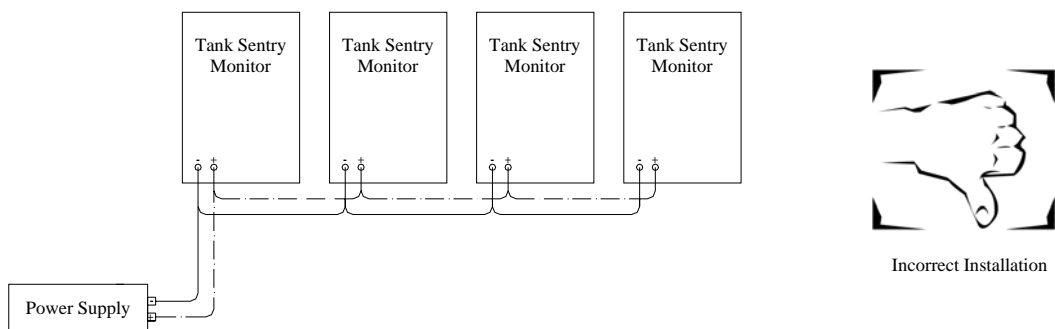

Incorrect Installation

WTS-1500 AND TS-1501 ONLY - SOLENOID OR RELAY CONNECTIONS

This monitor switches the DC negative side of a circuit controlling a solenoid or relay. The solenoid or relay is connected through terminals 3 and 4. Any DC device from 12 to 36 VDC and drawing up to 4 amps may be controlled.

- Connect terminal 3 to the negative side of the solenoid or relay.
- Connect terminal 4 to system negative.
- **Terminal 3 is polarity sensitive.**
- **Do not connect DC positive to terminal 3.**
- **Do not connect AC voltage to terminal 3 or 4.**

OPTIONAL REMOTE ALARMS

An optional remote alarm or any other 10 to 36 VDC device drawing up to 4 amps (e.g. pump relays or solenoids) may be connected through terminals 8 and 9 on the WTS-1500B, TS-1501B, and TS-2000B and on terminals 6 and 7 on the WTS-1100B and TS-2500B. These terminals switch the negative side of a DC device. They are normally open, close when the alarm is activated, and are unaffected by the mute switch.

Models WTS-1500B, TS-1501B, and TS-2000B:

- Connect terminal 8 to the negative side of the device.
- Connect terminal 9 to DC system negative.
- **Terminals 8 & 9 are polarity sensitive. If reversed, the alarm will be on all the time.**
- **Do not connect DC positive to terminal 8 or 9.**
- **Do not connect AC voltage to terminal 8 or 9.**

Models WTS-1100B and TS-2500B:

- Connect terminal 7 to the negative side of the device.
- Connect terminal 6 to DC system negative.
- **Terminals 6 & 7 are polarity sensitive. If reversed, the alarm will be on all the time.**
- **Do not connect DC positive to terminal 6 or 7.**
- **Do not connect AC voltage to terminal 6 or 7.**

CONNECTING WIRES TO THE SYM-23Q (R OR S) SENSOR MODULE

Connect the shielded 18/3 wire provided to the matching colors of the non-shielded wire at the SYM-23Q (R or S) Sensor Module. Use the pink heat-shrinkable butt connectors.

Do not connect the shield at the SYM Sensor Module.

FIGURE 5a: WTS-1100 AND TS-2500 CIRCUIT DIAGRAM

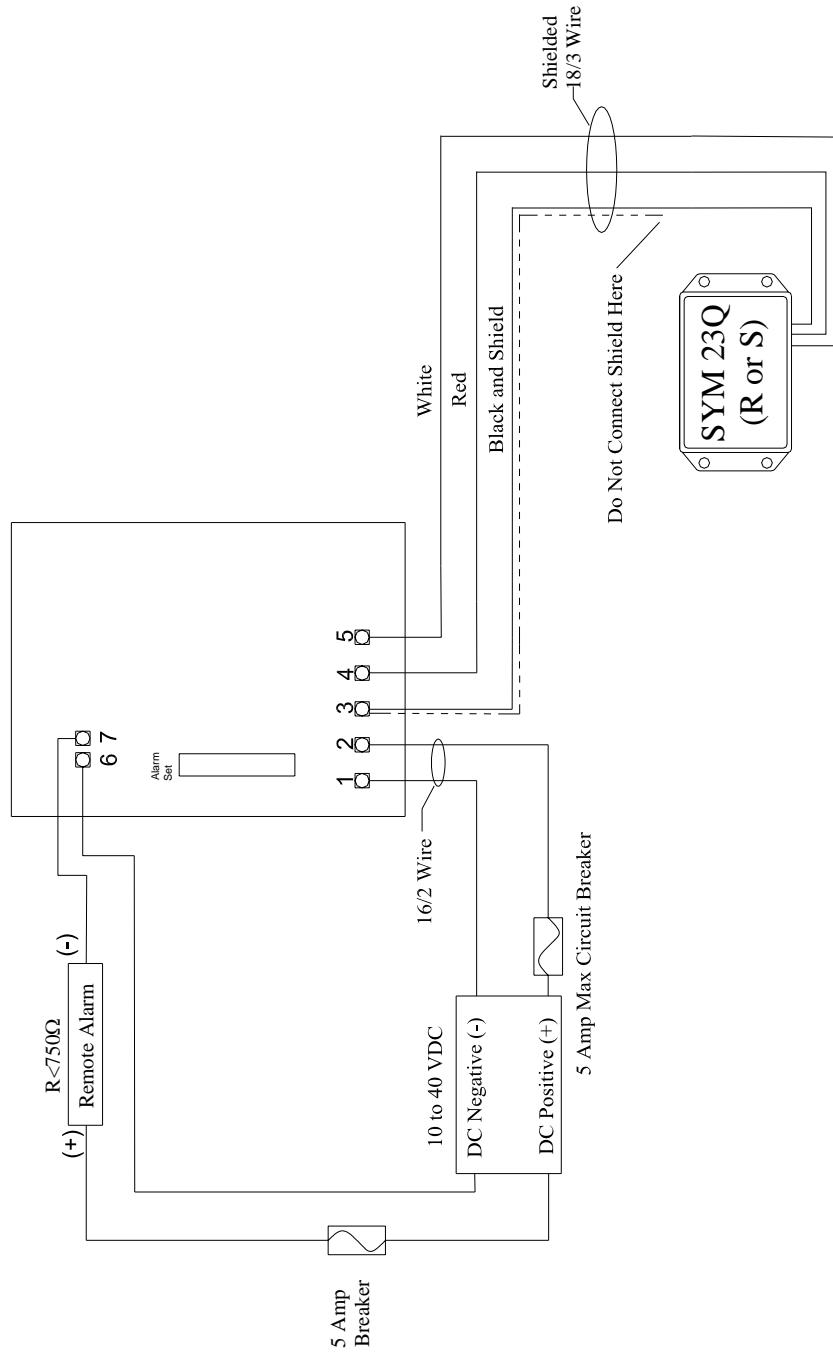

FIGURE 5b: TS-2000 CIRCUIT DIAGRAM

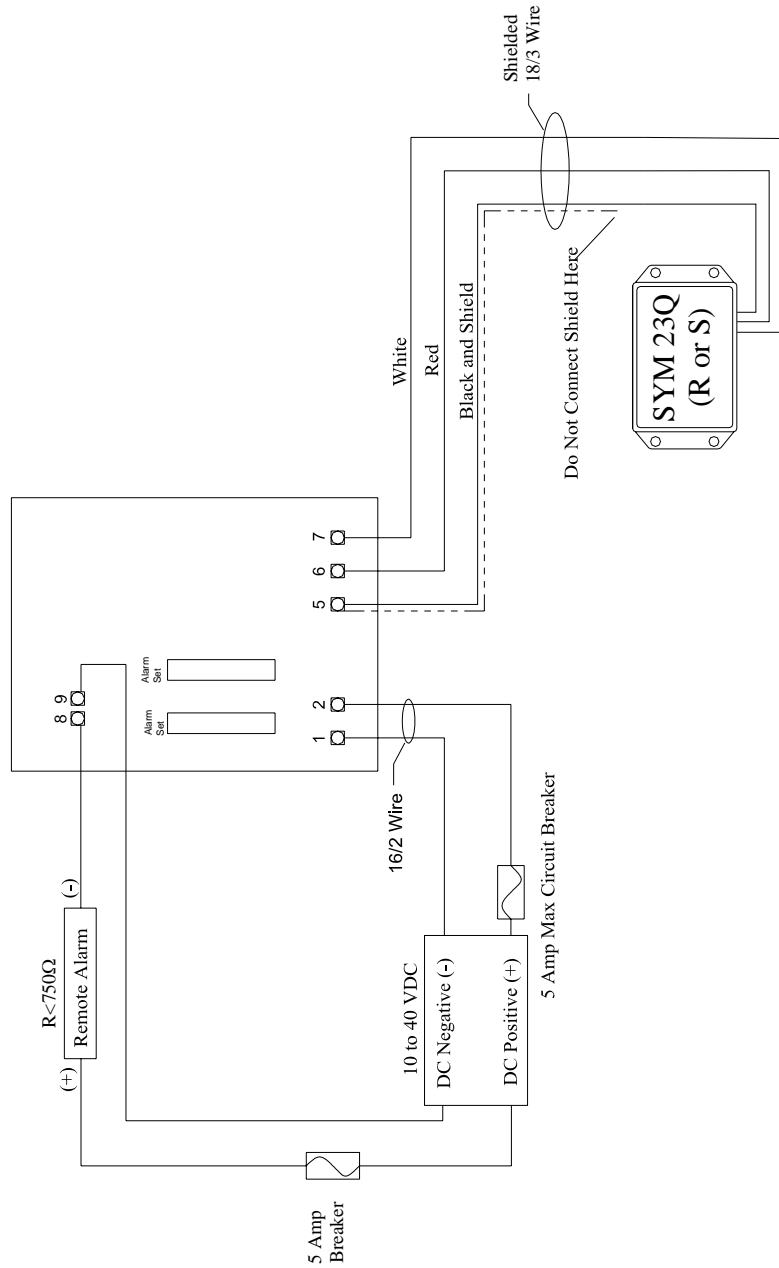

FIGURE 5c: WTS-1500B AND TS-1501B CIRCUIT DIAGRAM FOR AC PUMP

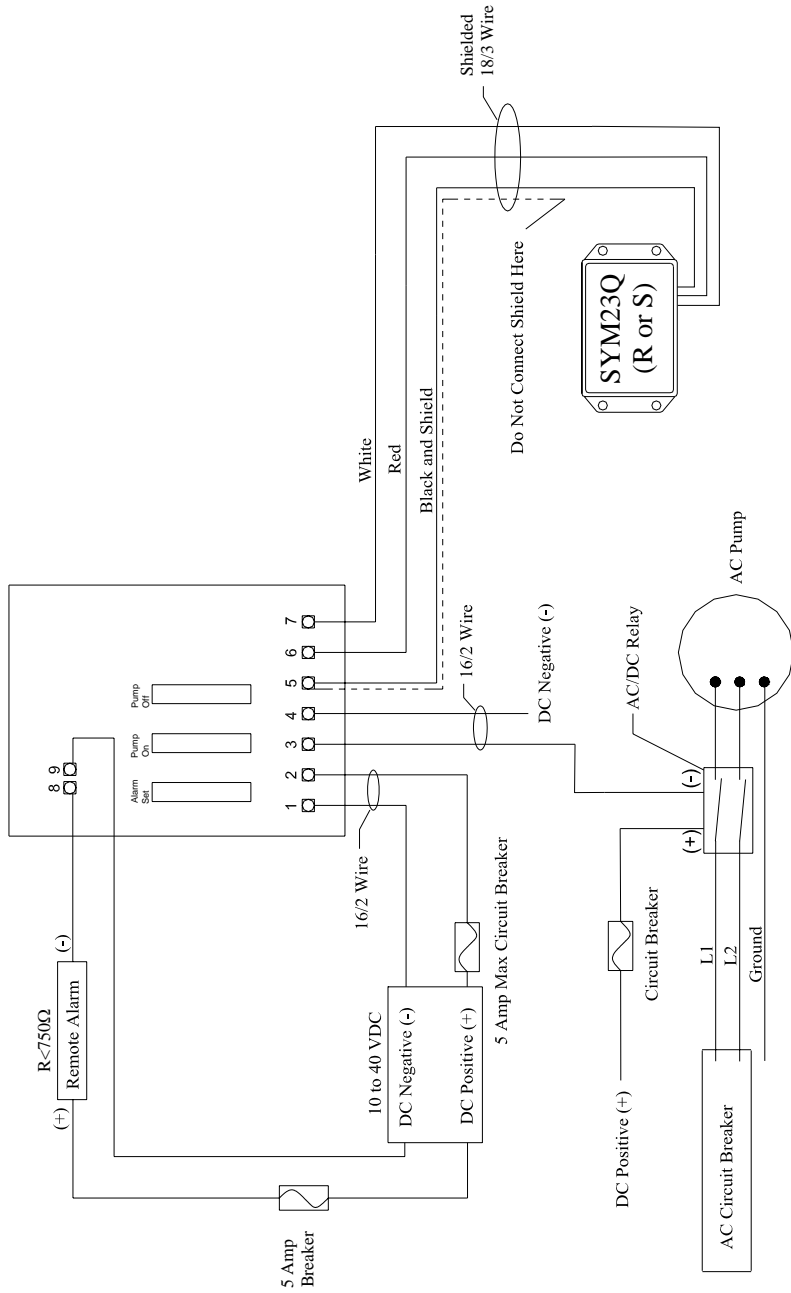
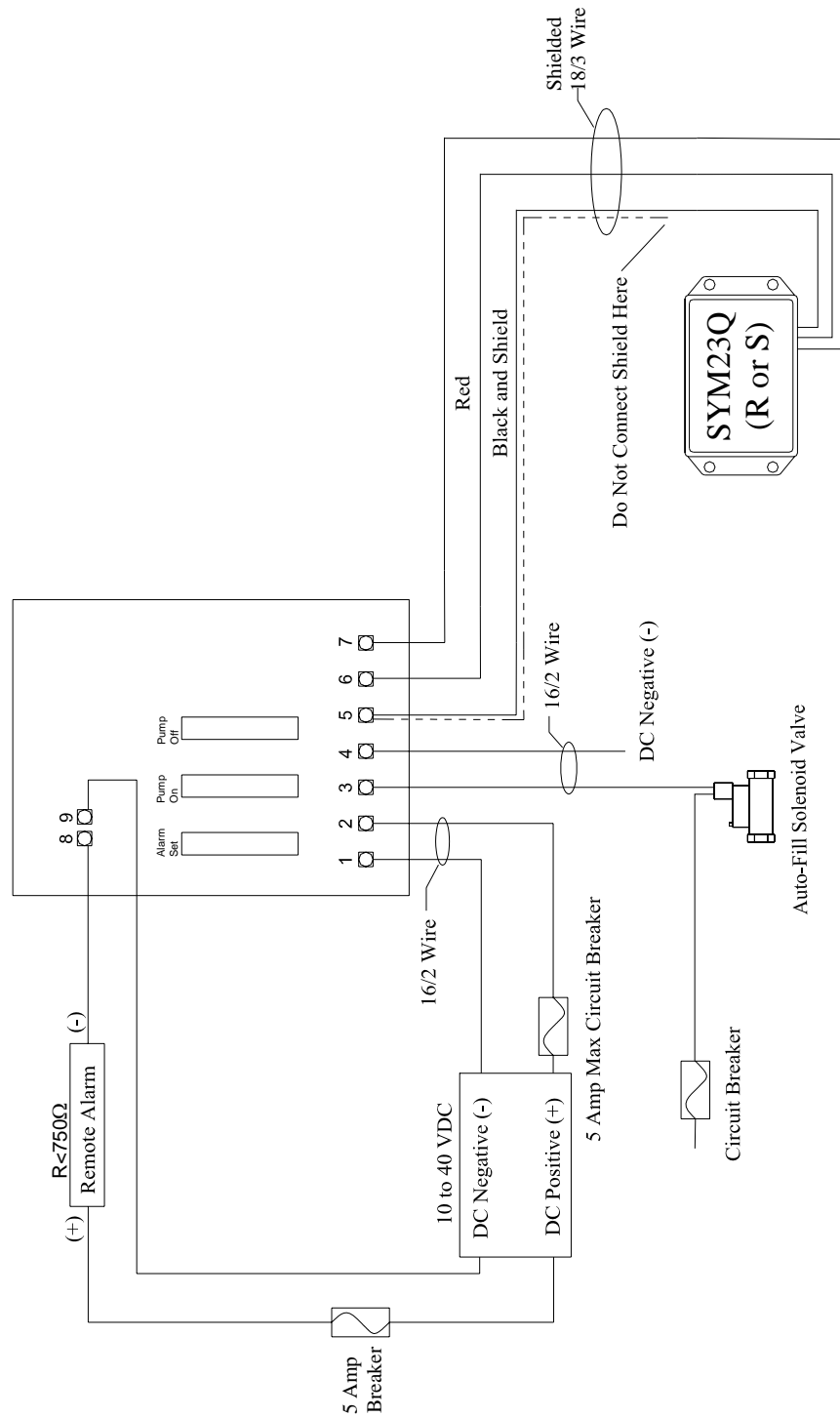

FIGURE 5e: TS-1501 SERIES CIRCUIT DIAGRAM FOR AUTO-FILL SOLENOID VALVE



ADJUSTING ALARMS ACTIVATION POINT (ALL MODELS)

On the back of the monitor panel are three linear, 10 position switches. The left-most switch is labeled "Alarm On" (The other two are for pump controls, discussed next). This switch sets the "on" position of the alarms (audible, visual, and remote) in 10% increments from 10% (position labeled "1") to 100% (position labeled "10"). When the fluid in the tank reaches the set position the alarms turn on.

- **Model TS-1501B, TS-2500, and TS-2000 only:** The alarms (audible, visual, and remote) stay on at the set point and all lower fluid levels.
- **Model WTS-1500B, TS-2000, and WTS-1100 only:** The alarms (audible, visual, and remote) stay on at the set point and all higher fluid levels.

Note: Audible alarm can be muted with front panel control. Visual and remote alarms are unaffected by the mute switch.

ADJUSTING AUTOMATIC PUMP CONTROLS

The two linear switches labeled "Pump On" & "Pump Off" control an external DC solenoid (or DC/AC relay if an AC pump is used) in 10% increments from 10% (position 1) to 100% (position 10).

- **Model WTS-1500B only:** When fluid in the tank rises to the position set on the "Pump On" switch, the solenoid (or relay) closes, turning the pump on, and stays closed until the tank level falls to the position set on the "Pump Off" switch. At this point the solenoid (or relay) opens, turning the pump off.
- **Model TS-1501B only:** When fluid in a tank falls to the position set on the "Pump On" switch, the solenoid (or relay) closes, turning the pump on, and stays closed until the tank level rises to the position set on the "Pump Off" switch. At this point the solenoid (or relay) opens, turning the pump off.
- **TS-1501B with an Auto-Fill Solenoid Valve:** when the fluid level in the tank drops below the "pump on" setting, the valve opens and will stay open until the level has risen to the "pump off" setting. At this point, the valve closes, shutting off the liquid fill.

CALIBRATION PROCEDURE FOR SYM-23QR

On the back of the monitor panel are two multi-turn trimpots, one red and one green. These are 25 turn trimpots, and cannot be damaged by over-rotating. They are used to set the zero and full readings on the monitor panel as outlined below.

Calibration is a simple three-step process that involves setting the empty reading, then the full reading, and finally, setting the empty reading again. Always make sure the tank is full (and not overfull!) when performing calibration.

Tip: A calibration kit is available from Headhunter that allows you to quickly simulate various depth tanks. It can save time, and is great for troubleshooting. Contact your Headhunter representative for more information.

1. Empty Setting. Perform with the power on and the tank empty (or disconnect the ¼" tubing from the SYM-23QR):

- The SYM LED will be flashing green.
- The green trimpot adjusts the zero (empty tank) LED readout. When all the LEDs are out, adjust the green trimpot counterclockwise to the point where the 10% light comes on.
- Then adjust the green trimpot clockwise to the point where the 10% light goes out. Continue turning an additional ½ turn in the clockwise direction.

Tip: The empty condition can be simulated by disconnecting the ¼" tubing from the SYM. After the empty has been set, reconnect the tubing and push the purge button on the SYM.

2. Full Setting. Fill the tank, but not overfill or “press” the tank or a false reading will occur. When all the fittings are assembled and in their permanent positions, push the purge switch on the SYM-23QR Sensor Module, the SYM will run for 15 seconds. Observe the indicator lights.

- The SYM LED will be continuously green (if not, see Appendix B).
- All the LEDs on the panel should be on. If all the LEDs are not on initially, check voltage between terminals (3 and 5 for 1100 and 2500, 5 and 7 for others) on the monitor panel to make sure voltage and tank depth correspond. A voltage / depth chart is in appendix C.
- Adjust the red trimpot counterclockwise until the top (100%) LED goes out, and then turn clockwise until the 100% LED just goes on, then continue to turn clockwise for a ½ turn. **STOP.** Go to the Empty Setting.

3. Empty Setting.

- **IMPORTANT:** Empty the tank (*or disconnect the ¼” tubing from the SYM-23QR*) and repeat the first procedure.
- The SYM LED will be flashing green.
- Reconnect all fittings and push the purge switch on the SYM-23QR Sensor Module to pressurize tubing.
- **STOP:** This completes the calibration.

Once the panel is correctly calibrated the panel will not need to be adjusted again.

The calibration procedure is illustrated in Figure 7.

IMPORTANT NOTE:

Don't forget to install the locking snap-rings around the collets of the quick-connections at the TIF-1250 and the SYM, as shown in Figures 1a, 2a, and 3a. These snap rings will prevent the tubing from becoming accidentally disconnected (For plastic series only).

Your Tank Sentry system is now ready for service!

If you have any questions or need further assistance, don't hesitate to call Headhunter Customer Service.

FIGURE 7: CALIBRATION PROCEDURE FOR SYM-23QR

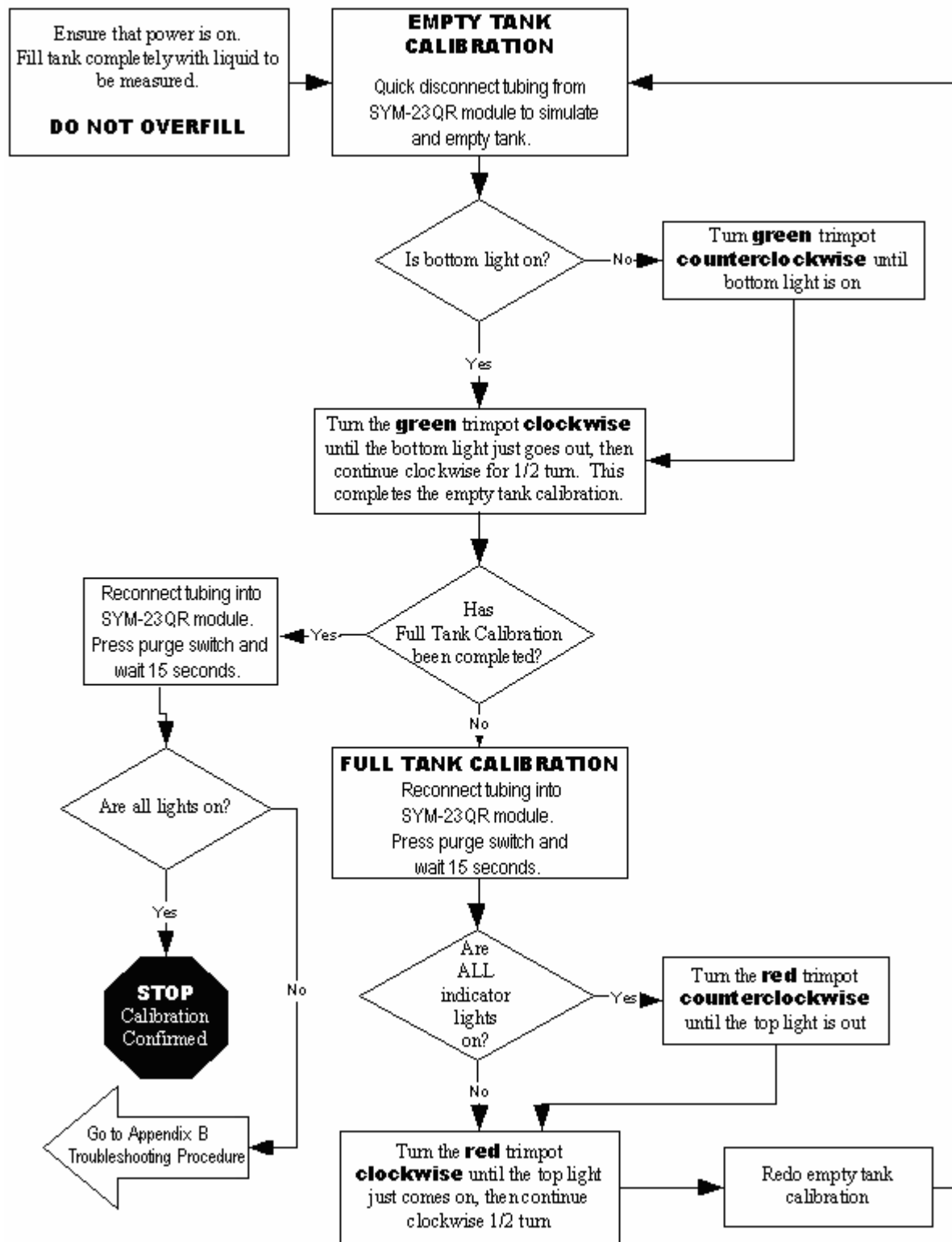

CALIBRATION PROCEDURE FOR SYM-23QS

On the back of the monitor panel are two multi-turn trimpots, one red and one green. These are 25 turn trimpots, and cannot be damaged by over-rotating. They are used to set the zero and full readings on the monitor panel as outlined below.

Calibration is a simple three-step process that involves setting the full reading, then the empty reading, and finally, setting the full reading again.

Tip: A calibration kit is available from Headhunter that allows you to quickly simulate various depth tanks. It can save time, and is great for trouble shooting. Contact your Headhunter representative for more information.

1. Full Setting. Fill the tank, but do not overfill or “press” the tank or a false reading will occur. When all the fittings are assembled and in their permanent positions, push the purge button on the SYM-23QS Sensor Module, the SYM will run for 15 seconds. Observe the indicator lights.

- The SYM-23QS LED will be continuously green.
- All the LEDs on the panel should be on. If all the LEDs are not on initially, check voltage between terminals (3 and 5 for 1100 and 2500, 5 and 7 for others) on the monitor panel to make sure voltage and tank depth correspond. A voltage / depth chart is in appendix C.
- Adjust the red trimpot counterclockwise until the top (100%) LED goes out, then turn clockwise until the 100% LED just goes on, then continue to turn clockwise for a ½ turn. STOP. Go to the Empty Setting.

2. Empty Setting. Perform with the power on and the tank empty (or tubing disconnected):

- The SYM-23QS LED will be flashing green.
- The green trimpot adjusts the zero (empty tank) LED readout. Turn green trimpot clockwise until all the LEDs are out, adjust the green trimpot counterclockwise to the point where the 10% light comes on.
- Then adjust the green trimpot clockwise to the point where the 10% light goes out. Continue turning an additional ½ turn in the clockwise direction.

Tip: The empty condition can be simulated by disconnecting the tubing from the SYM-23QS. After the empty has been set, reconnect the tubing and push the purge button on the SYM-23QS. The sending unit will automatically run for 15 seconds to pressurize the system.

3. Full Setting.

- Reconnect tubing to SYM-23QS.
- Push the purge button on the SYM-23QS.
- The SYM-23QS LED will be continuously green.
- Are all indicator lights on?
- **YES** = Turn the red trimpot counterclockwise until the top light goes out and then clockwise until the top light just goes on and then an additional ½ turn.
- **NO** = Turn the red trimpot clockwise until the top light just goes on and then an additional ½ turn.
- Calibration is complete.
- This Calibration Procedure is illustrated in Figure 8.

FIGURE 8: CALIBRATION PROCEDURE FOR SYM-23QS

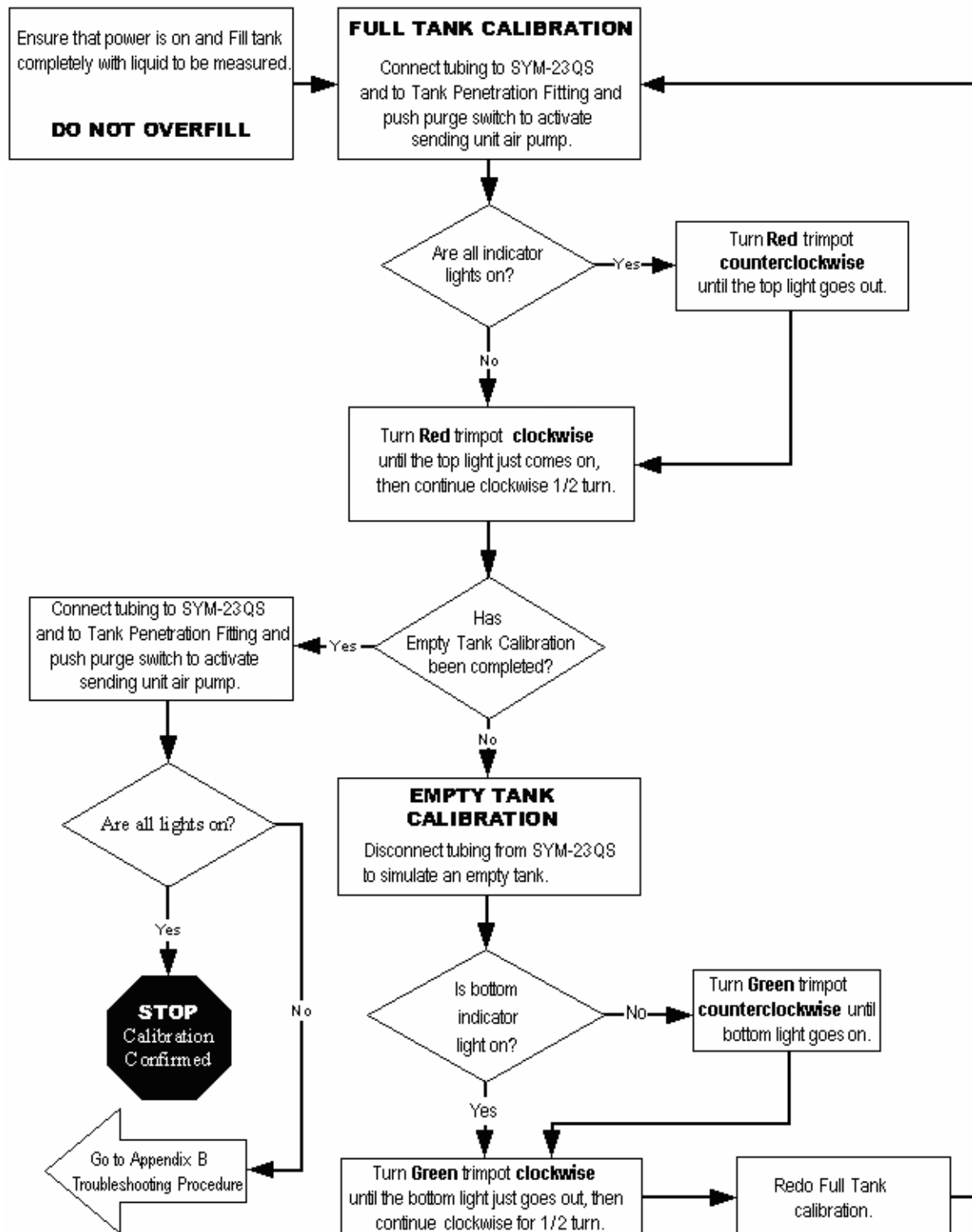

APPENDIX A: WIRING DIAGRAM FOR MASTER/SLAVE INSTALLATION

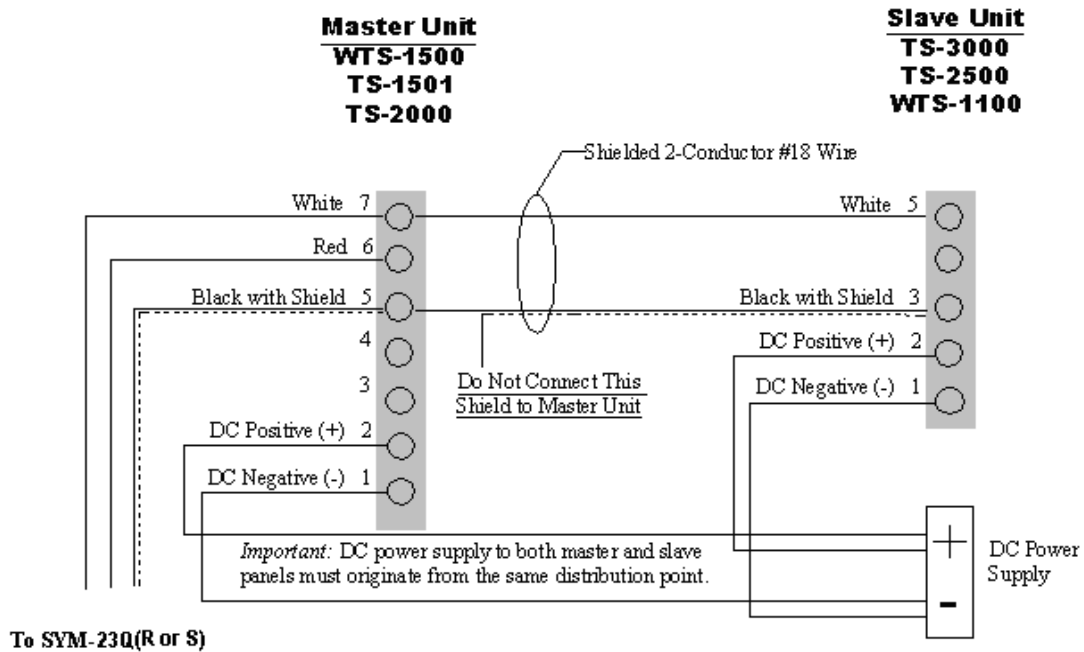
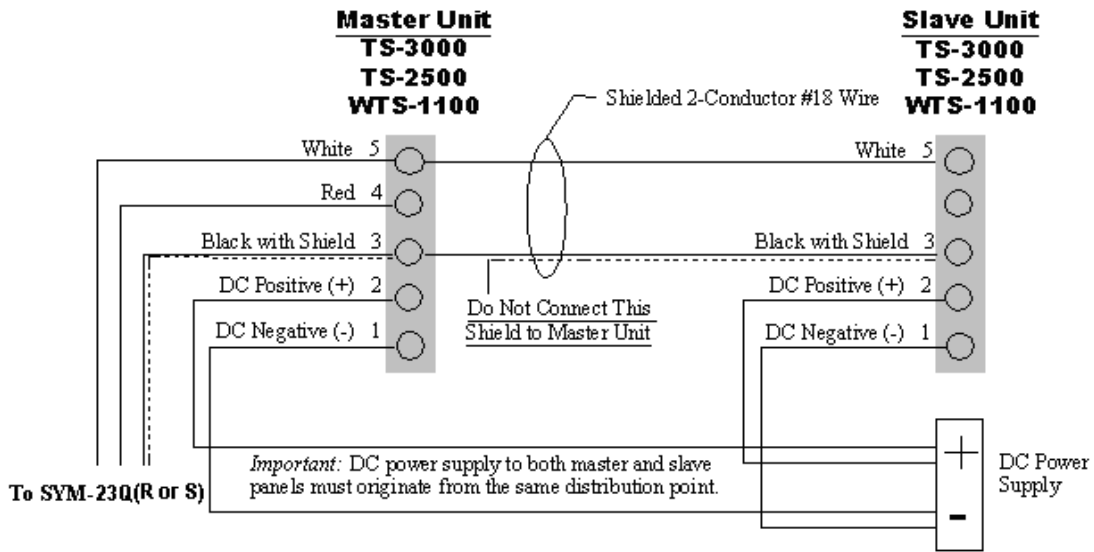

APPENDIX B: SYSTEM TROUBLE SHOOTING

Problem

Solution

The monitor always displays full.
(Continuous Green LED)

Is the tube plugged? Disconnect the tube from the SYM. The display should drop to 0. If not, check that the tube is not plugged.

Is the pressure transducer blown? Disconnect the tube from the SYM. If the display remains unchanged the pressure transducer may be blown.

Is your discharge pump working? If your discharge pump is not working, your tank will remain full.

Are your wires connected properly? A bad or nicked wiring connection could cause the display to be inaccurate. Double check all connections.

Was the tank properly calibrated? If the panel has worked in the past, you will not need to recalibrate panel.

Monitor spikes every 10 minutes.
(Continuous Green LED)

Is there a leak in the tube? This problem could be caused by loose or poor tubing connections. Cut ¼" off each end of the tube to check that the connection is tight. Check tube at SYM, TPA (Tank Penetration Assembly) and inside the tank.

Is the tube partially blocked? Check that the tube does not have anything lodged in the nylon tubing.

Monitor is full
(Blinking Green LED)

Was the tank properly calibrated? A blinking green LED means the SYM is reading an empty tank or there is a loose connection in the tubing. The panel may have been calibrated full with an empty tank. Recalibrate if necessary.

The monitor spikes when tank is filling or toilet is flushed.
(Continuous Green LED)

Is your tank properly vented? Make sure there are no vents that could trap liquids. ¾" or larger vents are recommended. Check that there are no bugs/nests/screens in the thru-hull fitting. Inline vent filters are not recommended.

The monitor drops rapidly after using the tank for the first time.
(Continuous Green LED)

Was the tank calibrated with an overfilled tank? If the liquid in your tank is in the vent line during calibration it will cause the tank to read artificially high. Calibration may need to be repeated with a full (not overfull!!!) tank.

Monitor spikes every 10 minutes.
(Blinking Red LED)

Is there a small leak in the tube? Check tubing and tubing connections for leaks.

No lights, no power, no nothing...

Were the panel and the SYM wired correctly? Check with figures 5a – 5e to check that the panel is correctly wired. If the problem is still there, consult Appendix C: Voltage Signals.

APPENDIX C: VOLTAGE SIGNALS

Checking the voltage is a quick way to isolate a problem, should one exist. The SYM has 3 wires (Black, Red and White) and the voltage between them will tell you the behavior of the system.

1. Voltage between Black and Red wires = 8 volts.

This means that the panel is sending power down to the SYM. The SYM will be properly powered and working. If the voltage is not 8 volts, check the voltage at the panel. If 8 volts is present, replace the SYM. If 8 volts is not present replace the panel or contact Headhunter.

2. Voltage between Black and White wires with air tube removed = 0.95 Volts for SYM-23QR and 0.5 Volts for SYM-23QS. Different voltages may indicate a bad SYM that should be replaced. Contact Headhunter.

3. Voltage between Black and White wires with tube installed and SYM purged for 10 seconds = see chart below. This voltage will correlate to the level in your tank. If the voltage signal does not agree with the chart below, check tubing connections to ensure an air tight seal. The problem may be improperly connected fittings resulting in an “empty tank” voltage when there should be a “full tank” voltage.

4. SYM voltage response between the Black and White wires may be tested by attaching a piece of tubing to the SYM and submerging the free end into a bucket of water. The voltage should rise as the tubing is submerged, this can isolate the problem to the SYM unit or the tubing / probe assembly in the tank.

Signal Voltage vs. Depth Table for Headhunter Tank Sentry Sending Units

SYM-23QR SENDING UNIT					
<u>Depth of Fluid</u>	<u>Signal Voltage</u>	<u>Depth of Fluid</u>	<u>Signal Voltage</u>	<u>Depth of Fluid</u>	<u>Signal Voltage</u>
(inches H2O)	VDC	(inches H2O)	VDC	(inches H2O)	VDC
0	0.95	45	2.53	90	4.12
1	0.99	46	2.57	91	4.16
2	1.02	47	2.60	92	4.19
3	1.06	48	2.64	93	4.23
4	1.09	49	2.67	94	4.26
5	1.13	50	2.71	95	4.30
6	1.16	51	2.74	96	4.33
7	1.20	52	2.78	97	4.37
8	1.23	53	2.81	98	4.40
9	1.27	54	2.85	99	4.44
10	1.30	55	2.88	100	4.47
11	1.34	56	2.92	101	4.51
12	1.37	57	2.95	102	4.54
13	1.41	58	2.99	103	4.58
14	1.44	59	3.02	104	4.61
15	1.48	60	3.06	105	4.65
16	1.51	61	3.09	106	4.68
17	1.55	62	3.13	107	4.72
18	1.58	63	3.16	108	4.75
19	1.62	64	3.20	109	4.79
20	1.65	65	3.23	110	4.82
21	1.69	66	3.27	111	4.86
22	1.72	67	3.30	112	4.89
23	1.76	68	3.34	113	4.93
24	1.80	69	3.38	114	4.97
25	1.83	70	3.41	115	5.00
26	1.87	71	3.45	116	5.04
27	1.90	72	3.48	117	5.07
28	1.94	73	3.52	118	5.11
29	1.97	74	3.55	119	5.14
30	2.01	75	3.59	120	5.18
31	2.04	76	3.62	121	5.21
32	2.08	77	3.66	122	5.25
33	2.11	78	3.69	123	5.28
34	2.15	79	3.73	124	5.32
35	2.18	80	3.76	125	5.35
36	2.22	81	3.80	126	5.39
37	2.25	82	3.83	127	5.42
38	2.29	83	3.87	128	5.46
39	2.32	84	3.90	129	5.49
40	2.36	85	3.94	130	5.53
41	2.39	86	3.97	131	5.56
42	2.43	87	4.01	132	5.60
43	2.46	88	4.04		
44	2.50	89	4.08		

SYM-23QS SENDING UNIT	
<u>Depth of Fluid</u>	<u>Signal Voltage</u>
(inches H2O)	VDC
0	0.500
1	0.653
2	0.806
3	0.959
4	1.112
5	1.266
6	1.419
7	1.572
8	1.725
9	1.878
10	2.031
11	2.184
12	2.337
13	2.491
14	2.644
15	2.797
16	2.950
17	3.103
18	3.256
19	3.409
20	3.562
21	3.716
22	3.869
23	4.022
24	4.175
25	4.328
26	4.481
27	4.634
28	4.787
29	4.940
30	5.094
31	5.247
32	5.400