



Solids Handling Diaphragm Pump



- Self-priming to 10 Ft.
- 1-1/2" Male NPT Inlet
- 1-1/2" Female NPT Discharge
- Dry Run Capability
- Reinforced Polypropylene Construction
- Neoprene Diaphragms and Valves
- 316 Stainless Steel Shaft and Hardware
- Washdown Duty Motors

The Tortuga is an aggressive solids handling diaphragm pump constructed of a lightweight corrosion proof glass reinforced polypropylene. This pump is ideal for sewage, gray water, fish box and bilge applications where reliability is a premium. Its' solids handling and self-priming properties make it ideal for transferring waste from holding tanks into sewage treatment systems or overboard. All pumps are equipped with 1-1/2 inch NPT fittings for fast, easy installation.

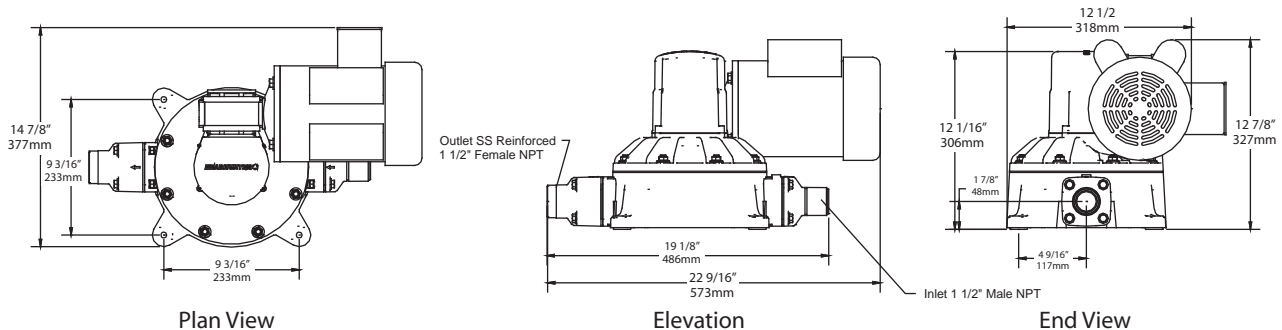

PART #	VOLTAGE	AMPS	Breaker Size
TORTUGA PUMP 1/2 HP Self Priming Diaphragm Pump			
TOR-12	12VDC	24	45
TOR-24	24VDC	12	25
TOR-1P60	115/230 VAC 1ph 60hz	8.8/4.4	15/10
TOR-1P50	220VAC 1ph 50hz	3.2	5
TOR-3P60	208-230/440 VAC 3ph 60hz	2.0/1.0	5
TOR-3P50	220/380/440 VAC 3ph 50hz	2.0/1.0	5

PERFORMANCE

Delivery (Flow): 10 GPM (38 lpm)
 Max Suction lift: 10 ft. (3 m)
 Max Discharge (Head): 15 ft. (4.6 m)
 Weight: 43 lbs (19.5 kg)

3380 SW 11TH AVENUE
 FORT LAUDERDALE, FLORIDA 33315
 PHONE: +1 954-581-6996
 FAX: +1 954-587-0403



HEADHUNTER
 WWW.HEADHUNTERING.COM